

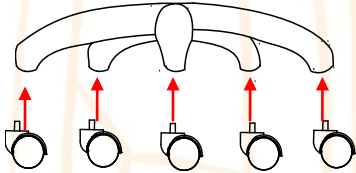

# CARIBOU

## CHAIR ASSEMBLY INSTRUCTIONS

Step 1. Insert Castors into the Base.



Step 2. Insert the cylinder into the pre-assembled Base.

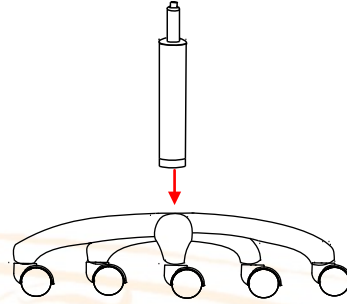

Step 3 . Place The Telescopic on top of the Cylinder (not on all models)

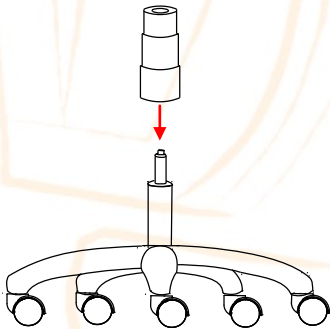

Step 4 . Align the Back Support with the Control and secure the back using the back bolts

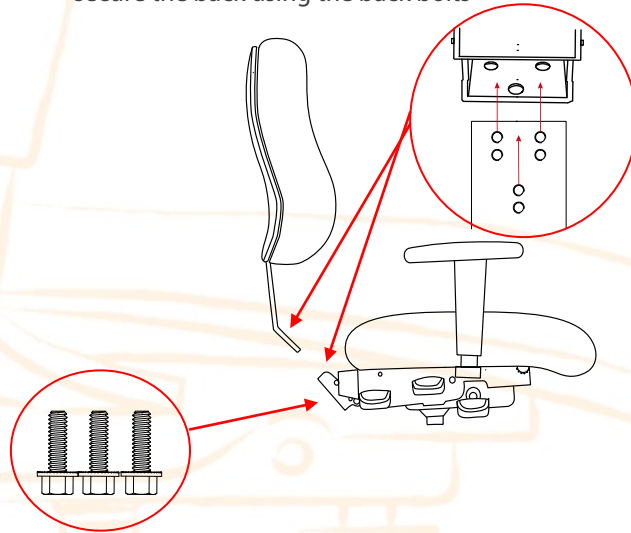

Step 5 . Place the chair on top of the pre-assembled cylinder & base

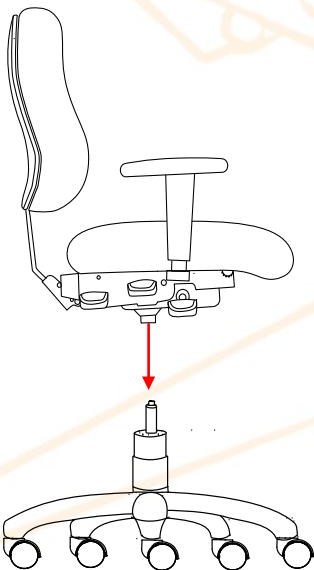

[www.caribouoffice.com](http://www.caribouoffice.com)

(720) 378-5664